



# JOURNEY through the UNIVERSE

## VOYAGE: A JOURNEY THROUGH OUR SOLAR SYSTEM

GRADES 5-8

### LESSON 5: ROUND AND ROUND WE GO – EXPLORING ORBITS IN THE SOLAR SYSTEM

On a visit to the National Mall in Washington, DC, one can see monuments of a nation—Memorials to Lincoln, Jefferson, and WWII, the Vietnam Veterans Memorial Wall, and Washington Monument. Standing among them is *Voyage*—a one to 10-billion scale model of our Solar System—spanning 2,000 feet from the National Air and Space Museum to the Smithsonian Castle. *Voyage* provides visitors a powerful understanding of what we know about Earth's place in space and celebrates our ability to know it. It reveals the true nature of humanity's existence—six billion souls occupying a tiny, fragile, beautiful world in a vast space.

*Voyage* is an exhibition that speaks to all humanity. The National Center for Earth and Space Science Education is therefore making replicas of *Voyage* available for permanent installation in communities worldwide (<http://voyagesolarsystem.org>.)

This lesson is one of many grade K-12 lessons developed to bring the *Voyage* experience to classrooms across the nation through the Center's *Journey through the Universe* program. *Journey through the Universe* takes entire communities to the space frontier (<http://journeythroughtheuniverse.org>.)

The *Voyage* exhibition on the National Mall was developed by Challenger Center for Space Science Education, the Smithsonian Institution, and NASA.

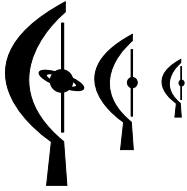

## LESSON 5: ROUND AND ROUND WE GO— EXPLORING ORBITS IN THE SOLAR SYSTEM

### LESSON AT A GLANCE

#### LESSON OVERVIEW

To appreciate the complexity of the Solar System requires an understanding that it is a dynamic system—a system in motion. Objects bound to the Sun by gravity—planets, dwarf planets, comets, asteroids, and trans-neptunian (or Kuiper Belt Objects)—follow elliptical orbits around the Sun. Students first explore the geometric nature of ellipses, and the circle as a special case. These newly developed mathematical skills are then used to plot an accurate model of the outer Solar System, which contains the size, eccentricity, and orientation in space of the orbits for different classes of objects. Students are then able to understand how orbits can be used to help categorize objects in the Solar System.

#### LESSON DURATION

Two or three 45-minute classes



#### CORE EDUCATION STANDARDS

##### *National Science Education Standards*

##### Standard D3: Earth in the solar system

- The earth is the third planet from the sun in a system that includes the moon, the sun, eight other planets and their moons, and smaller objects, such as asteroids and comets. The sun, an average star, is the central and largest body in the solar system.
- Most objects in the solar system are in regular and predictable motion. Those motions explain such phenomena as the day, the year, phases of the moon, and eclipses.
- Gravity is the force that keeps planets in orbit around the sun and governs the rest of the motion in the solar system. Gravity alone holds us to the earth's surface and explains the phenomena of the tides.

*AAAS Benchmarks for Science Literacy***Benchmark 4A3:**

Nine planets\* of very different size, composition, and surface features move around the sun in nearly circular orbits. Some planets have a variety of moons and even flat rings of rock and ice particles orbiting around them. Some of these planets and moons show evidence of geologic activity. The earth is orbited by one moon, many artificial satellites, and debris.

*\* Since the time these standards were written, the International Astronomical Union decided that there are only eight major planets in the Solar System. The former ninth planet, Pluto, is considered a dwarf planet.*

**ESSENTIAL QUESTIONS**

- ▶ What is an ellipse?
- ▶ What is the nature of orbits of various Solar System objects?

**CONCEPTS**

Students will learn the following concepts:

- ▶ A circle is an ellipse with both foci located at the same point.
- ▶ The orbits of planets (and most other objects in the Solar System) around the Sun are ellipses with the Sun located at one focus.
- ▶ The shapes of the orbits of comets are different from the orbits of planets.

**OBJECTIVES**

Students will be able to do the following:

- ▶ Draw a circle and an ellipse, and understand their similarities and differences.
- ▶ Plot planetary orbits and compare them to orbits of other Solar System objects.
- ▶ Classify Solar System objects based on their orbits.

## SCIENCE OVERVIEW

As long as people have observed planets, they have sought to explain their movement in the sky. Because the classical planets—Mercury, Venus, Mars, Jupiter and Saturn—can be seen easily with the unaided eye, this quest goes back as far as history can be traced. In ancient times, people usually thought that the Earth was at the center of the Universe, with the Sun, the Moon, and the planets moving around the Earth in perfect circles. However, this system was not able to explain the observed motions of the planets properly. The breakthrough in explaining the motions of the planets came in the 16th and 17th centuries, when Nicolaus Copernicus (1473-1543) introduced the heliocentric model, which placed the Sun at the center of the Solar System (which then was thought to be pretty much the whole Universe), and when Johannes Kepler (1571-1630) suggested that using ellipses instead of circles is the best way to explain the motions of the planets.

### ELLIPSES AND CIRCLES

An ellipse is a geometrical shape that looks much like a squashed circle. To draw one, tie the ends of a string around two fixed points that are placed on a piece of paper (see Figure 1). With a pencil, draw a curve by pulling the string taut and sweeping it around the paper. The places where the two points are located are called the ellipse's foci (plural of focus). The length of the long axis of the ellipse is called its major axis. The smaller axis, perpendicular to the major axis, is called the minor axis (see Figure 2).

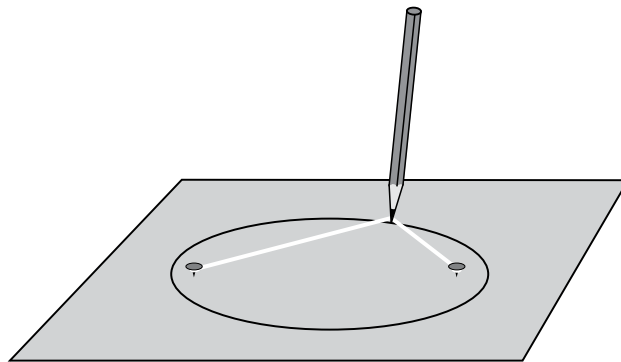

*Figure 1: Drawing an ellipse with string and tacks.*

How stretched out an ellipse is can be described by a quantity called eccentricity. An ellipse's eccentricity is calculated by dividing the distance between the ellipse's foci by the length of the major axis:

$$\text{eccentricity} = \frac{\text{distance between foci}}{\text{length of major axis}}$$

If an ellipse has an eccentricity of zero, it is a perfect circle. In this case, the two foci are located in the same place: the circle's center. If an ellipse has an eccentricity close to one, it is very long and narrow. Ellipses cannot have eccentricities greater than or equal to one, or less than zero.

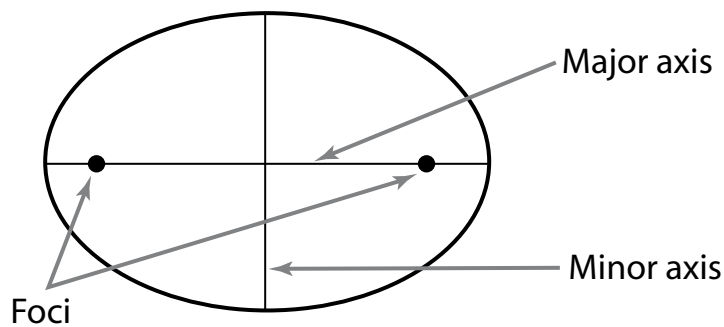

Figure 2: The properties of an ellipse can be described by the location of its foci and the lengths of its major and minor axes.

#### KEPLER'S LAWS

Johannes Kepler (1571-1630) was a German astronomer who strived to find a mathematical way to describe the planets' movements in space. By the 17th century it was clear that the explanation of planetary motions using perfect circles was not adequate. In 1609, Kepler stated his first of three laws of planetary motion: the orbit of each planet is an ellipse, with the Sun located at one focus. While Kepler's first law only mentions planets, it also applies to other objects that orbit the Sun, such as dwarf planets, comets, asteroids, icy worlds in the outer parts of the Solar System called Kuiper Belt Objects, and even tiny dust particles. Note that objects that orbit another body and not the Sun (such as the planets' moons or the particles that make up the rings of Jupiter, Saturn, Uranus and Neptune) also orbit their host body in elliptical orbits.

Kepler's other two laws further define the orbits of the planets. The second law states that if an imaginary line is drawn from the planet to the Sun, the size of the area of the ellipse that the line moves over as the planet moves on its orbit during a given time is the same, regardless of where the planet is on its orbit. This means that planets move faster in their orbit when they are closer to the Sun and slower when they are farther away (see Figure 3).

Round and Round We Go

Lesson at a Glance

Science Overview

Conducting the Lesson

Resources

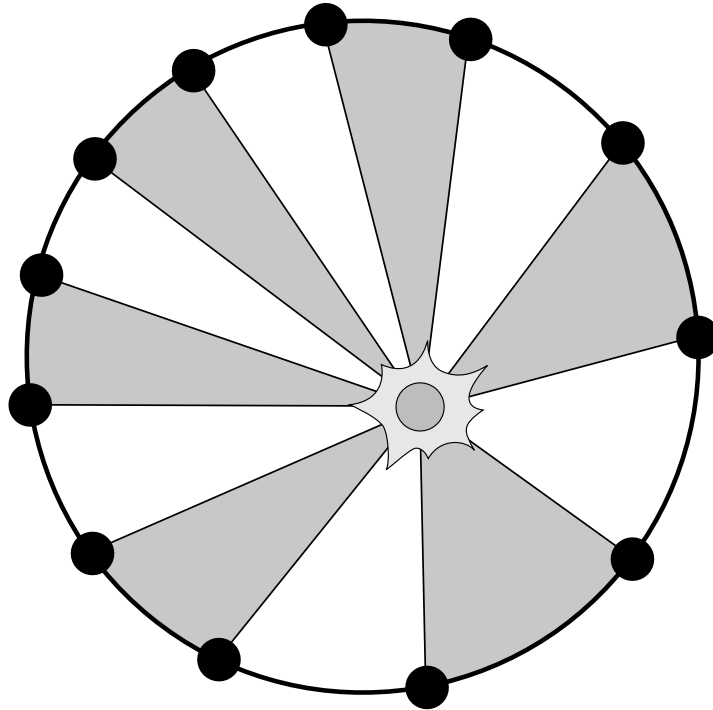

Figure 3: Kepler's second law states that the amount of area swept over during any time interval of a planet's orbit is the same, regardless of where the planet is on its orbit. Each black dot in the figure above represents a planet at equal time intervals on its orbit around the Sun. Therefore, according to Kepler's Second Law, each of the shaded regions are equal in area. Note that this means the planet must move faster in its orbit when it is closer to the Sun than when it is farther away. NOTE: Not to scale.

Kepler's third law states that a planet's orbital period (the time it takes to orbit the Sun once) is related to its major axis: the square of the period ( $T_{yr}$ ) is proportional to the cube of half of the length of the orbit's major axis ( $A_{AU}$ ), and roughly equal if the length of the period is expressed in Earth years, and the length of the major axis in AU (one astronomical unit—AU—is the average distance between the Earth and the Sun and is equal to 150 million km, or 93 million miles.) That is,

$$(T_{yr})^2 \approx (1/2 \times A_{AU})^3.$$

For Earth, this relationship is exact (1 Earth year, 1 AU). The theoretical basis for Kepler's laws was explained by Sir Isaac Newton (1642-1727) when he presented his theory of gravitation: the planetary orbits are a manifestation of the gravitational interaction between the planets and the Sun.

### PLANETARY ORBITS VS. ORBITS OF OTHER SOLAR SYSTEM OBJECTS

In general, the eccentricity of all planetary orbits is small; they orbit the Sun in almost perfect circles. The exception to this rule is Mercury, whose orbit is heavily influenced by its close proximity to the Sun. This may explain Mercury's high orbital eccentricity. The orbits of other objects in the Solar System vary a great deal, and many objects have highly eccentric orbits. The orbits of comets are in general quite eccentric, approaching values close to 1. The orbits of planets and comets define the two orbital extremes in the Solar System. The orbits of the other objects, such as asteroids, dwarf planets, and Kuiper Belt Objects, fit between these two extremes.

Orbital considerations are important for classifying objects in the Solar System. For example, Pluto's high eccentricity as compared with the planets was one of the reasons scientists had long debated whether the object really was a planet, as it had been classified since its discovery in 1930, or another kind of object. For example, its orbit is similar to those of Kuiper Belt Objects rather than the orbits of planets. As a result, it was no surprise to those familiar with the characteristics of the orbits of different Solar System objects that when one of the objects in the Kuiper Belt region (called Eris) was discovered to be larger than Pluto, the International Astronomical Union decided in 2006 that Pluto cannot be considered a real planet any more, and, instead, belongs to a new class of objects called dwarf planets.

Another important characteristic of orbits is their inclination—that is, how much the plane in which the object orbits the Sun is angled with respect to the plane of Earth's orbit. The inclination of most of the planets is low: they orbit the Sun in pretty much the same plane. The inclinations of cometary orbits vary a great deal, again providing the end piece to the range of orbits in the Solar System. For the present purposes, we concentrate on the shape of orbits instead of their inclination, but it is good to remember that the orbits are located in a three-dimensional space instead of just on one plane.

Round and Round We Go

Lesson at a Glance

Science Overview

Conducting the Lesson

Resources

**Orbital parameters for planets,  
as well as sample dwarf planets, comets, asteroids and Kuiper Belt Objects**

	Distance from the Sun (AU; Earth-Sun distance)	Length of major axis (AU; Earth-Sun distance)	Orbital eccentricity	Orbital period (Earth years)
<b>PLANETS</b>				
Mercury	0.387	0.774	0.2056	0.241
Venus	0.723	1.446	0.0067	0.615
Earth	1	2	0.0167	1
Mars	1.524	3.048	0.0935	1.881
Jupiter	5.204	10.408	0.0489	11.862
Saturn	9.582	19.164	0.0565	29.457
Uranus	19.201	38.402	0.0457	84.011
Neptune	30.047	60.094	0.0113	164.79
<b>SAMPLE DWARF PLANETS</b>				
Ceres	2.767	5.534	0.0789	4.60
Pluto	39.482	78.964	0.2488	247.68
Eris	67.90	135.80	0.4362	560
<b>SAMPLE COMETS</b>				
Halley	17.94	35.88	0.967	76.1
Wild 2	3.44	6.88	0.540	6.39
Hale-Bopp	250	500	0.995	4,000
Hyakutake	1,165	2,330	0.9998	40,000
<b>SAMPLE KUIPER BELT OBJECTS</b>				
Quaoar	43.500	86.999	0.0349	287
Ixion	39.583	79.165	0.241	249
Varuna	43.007	86.014	0.0512	282
Chaos	45.651	91.301	0.104	308
<b>SAMPLE ASTEROIDS</b>				
Pallas	2.774	5.548	0.2299	4.61
Juno	2.669	5.338	0.2579	4.36
Vesta	2.362	4.724	0.0895	3.63

(Data for planets, comets, and asteroids from NASA's National Space Science Data Center, <http://nssdc.gsfc.nasa.gov/planetary>; data for Kuiper Belt Objects from <http://www.ifa.hawaii.edu/faculty/jewitt/kb.html> and <http://cfa-www.harvard.edu/~graff/Ephemerides/Distant/>)



**NOTES:**

Round and  
Round We Go

Lesson at a Glance

Science Overview

Conducting the  
Lesson

Resources

## CONDUCTING THE LESSON

### WARM-UP & PRE-ASSESSMENT



#### TEACHER MATERIALS

- 2 paper clips
- Transparent tape
- A blank overhead transparency
- Overhead projector
- Overhead marker
- 1 piece of string, approximately 25 cm (10 in) long

#### STUDENT MATERIALS

- (Optional): One sheet of notebook paper

#### PREPARATION & PROCEDURES

1. Create the transparency device you will need for the Warm-up & Pre-assessment (see the figure below). To do so, place a paper clip flat on top of a blank overhead transparency, and bend the end of the paper clip wire straight up in the air. Tape the paper clip to the central lower part of the transparency. Bend the wire of the second paper clip the same way, but do not tape it on the transparency.

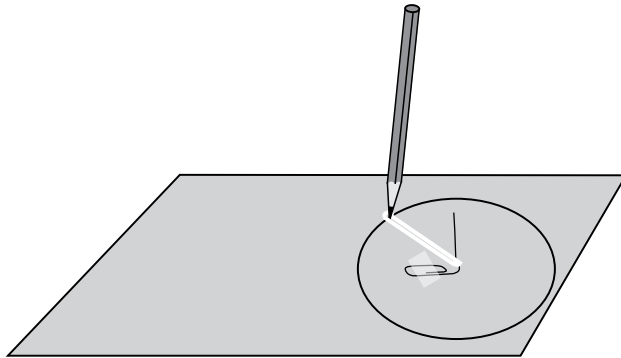

2. Set up the overhead projector. Ask the students to raise their hands if they think they can draw a perfect circle on the overhead. Ask them what would they need to make it accurate? (*Desired answer: they would need a sturdy point in the middle, and some way to keep the marker at the same distance from the sturdy point as they draw a circle; for example, a string connecting the marker and the central point*)

- Place the transparency with the paper clip on the overhead projector. Tie each end of the 25-cm long piece of string around the paper clip wire, place the marker in the loop created this way, pull the string taut, and draw a circle on the transparency (see the figure on the previous page.)

- Ask the students what would happen if you taped another paper clip to the transparency, tied one end of the string around each paper clip, and drew a figure the same way. What shape would you make? Take a few suggestions—or have students draw their suggestions individually on a piece of paper—and then tape the second paper clip a few inches above the first on the transparency. Tie one end of the string to each of the paper clips, pull the string taut with the marker, and sweep the marker on the paper from side to side, keeping the string taut, in order to create one half of the ellipse. To create the other half of the ellipse, remove the marker, move the string to the other side of the paper clips from the half of the ellipse you just drew, place the marker back on the string and draw the other half of the ellipse. See the figure below for the complete setup.

TEACHING TIP

Make sure that the string does not slide up or down the paper clip when you draw the circle and the ellipse. You can prevent this by making sure you tape the paper clip to the transparency right at the base of the rising arm and place a strip of tape on the arm, leaving just the base of the arm bare, so that the string can loop around the bare section but cannot rise or fall as you draw.

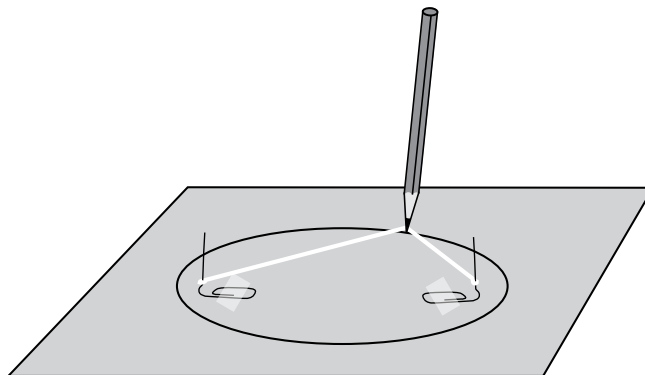

- Have students predict what would happen if you moved the paper clips closer together or further apart. Explain that they will experiment with ellipses to find out the answer in Activity 1.

Round and Round We Go

Lesson at a Glance

Science Overview

Conducting the Lesson

Warm Up & Pre-Assessment

Activity 1:  
*Ellipses are Eccentric!*

Activity 2:  
*The Eccentricities of Solar System Objects: How Crazy Are They?*

Lesson Wrap-Up

Resources

### ACTIVITY 1: ELLIPSES ARE ECCENTRIC!

Students will learn how to draw ellipses using a length of string whose ends are connected to two points in space (the foci). Students will explore how the geometry of an ellipse changes by varying the length of the string (equal to the length of the ellipse's major axis) and varying the distance between the foci.



#### STUDENT MATERIALS

(PER STUDENT OR PAIR OF STUDENTS)

- 2 paper clips
- Transparent tape
- Pen or pencil
- String (at least 25 cm, or 10 inches, long)
- Scissors
- A piece of paper (letter-size paper works well)
- Student Worksheet 1
- Student Worksheet 2

#### PREPARATION & PROCEDURES

1. Place students in pairs.
2. Review the terminology with the students. They will be creating an ellipse. The places where the two paper clips are located are called the ellipse's foci (plural of focus). The length of the long axis of the ellipse is called its major axis. The small axis perpendicular to the major axis is called the minor axis. (See Figure 2 in *Science Overview* or Figure S2 in Student Worksheet 1.)
3. Have students complete Student Worksheet 1. Make sure that they set up their paper clips and ellipse templates correctly. After the activity is completed, use the questions in the *Reflection & Discussion* section to lead the students to the understanding of eccentricity. Then have students complete Student Worksheet 2.

#### REFLECTION & DISCUSSION

1. As a class, discuss the results. Be sure to discuss an important property of ellipses: the sum of the distances to the foci remains the same no matter where the point is on the ellipse. You can use the following facilitation:

Ask the students what remains constant as the circle was drawn in the *Warm-up & Pre-assessment*. (*Desired answer: the radius*) How did we ensure that to be the case? (*Desired answer: the length of the string from the marker to the paper clip is the same as the radius of the circle, and the length of the string did not change*) Did the length of the string change when we were creating the ellipses? (*Desired answer: no*) Did the distance to each focus change? (*Desired answer: yes*) Then what does the length of the string represent? (*Desired answer: the sum of the distances to the foci*) Therefore, although the distance to each focus varies at different points along the ellipse, the sum of the distances to the foci remains the same no matter where the point is on the ellipse, and the sum is the length of the string.

2. Discuss how eccentricity is the property that decides the shape of an ellipse. You can use the following facilitation, which follows the questions in Student Worksheet 1: What happened when the two foci were placed further apart? (*Desired answer: the ellipse was less circular*) What happened when the string became shorter? (*Desired answer: the ellipse was less circular*) What would happen if the foci were very far apart, but the string was very long? (*Desired answer: the ellipse would be more circular.*) What is the real property that defines the shape of the ellipse? (*Desired answer: the ratio of the distance between the foci and the length of the string*) Tell the students that this ratio is called the eccentricity of the ellipse.

**TRANSFER OF KNOWLEDGE**

Refer to the *Transfer of Knowledge* section in Student Worksheet 2.

**PLACING THE ACTIVITY WITHIN THE LESSON**

Discuss with students how planets orbit the Sun, and what is meant by the word “orbit.”

Discuss Earth’s orbit around the Sun. It is very close to, but not exactly, a perfect circle. In fact, Earth (as well as the other planets) travels in an ellipse around the Sun. In Activity 2, students will model how the objects in the Solar System orbit the Sun.

**Round and Round We Go**

Lesson at a Glance

Science Overview

**Conducting the Lesson**

*Warm Up & Pre-Assessment*

**Activity 1:**  
*Ellipses are Eccentric!*

**Activity 2:**  
*The Eccentricities of Solar System Objects: How Crazy Are They?*

*Lesson Wrap-Up*

**TEACHING TIP**

Depending on the level of your students, you can let them manipulate their string and paper clips to help them with the *Transfer of Knowledge* questions, or you can have them figure out the questions without visual help.

Resources



### ASSESSMENT CRITERIA FOR ACTIVITY 1

#### 5 Points

- ▶ Student Worksheet 1 is complete and accurate.
- ▶ Questions were answered completely and accurately in Student Worksheet 2.
- ▶ Student drew an accurate ellipse in Student Worksheet 2

#### 4 Points

- ▶ Student Worksheet 1 is complete and mostly accurate.
- ▶ Questions were answered completely and mostly accurately in Student Worksheet 2.
- ▶ Student drew an accurate ellipse in Student Worksheet 2

#### 3 Points

- ▶ Student Worksheet 1 is complete and somewhat accurate.
- ▶ Questions were answered completely and somewhat accurately in Student Worksheet 2.
- ▶ Student drew an accurate ellipse in Student Worksheet 2.

#### 2 Points

- ▶ Student answered most of the questions in Student Worksheet 1, and answers are somewhat accurate.
- ▶ Student answered most of the questions in Student Worksheet 2, and the answers are somewhat accurate.
- ▶ Student drew an almost accurate ellipse in Student Worksheet 2.

#### 1 Point

- ▶ Student Worksheet 1 is somewhat accurate.
- ▶ Student answered several of the questions in Student Worksheet 2, and the answers are somewhat accurate.
- ▶ Student attempted to draw an ellipse in Student Worksheet 2.

#### 0 Points

- ▶ No work completed.

NOTES ON ACTIVITY 1:

**Round and Round We Go**

Lesson at a Glance

Science Overview

**Conducting the Lesson**

*Warm Up & Pre-Assessment*

**Activity 1:**  
*Ellipses are Eccentric!*

*Activity 2:*  
*The Eccentricities of Solar System Objects: How Crazy Are They?*

*Lesson Wrap-Up*

Resources

## ACTIVITY 2: THE ECCENTRICITIES OF SOLAR SYSTEM OBJECTS: HOW CRAZY ARE THEY?

Students will plot the elliptical orbits of different classes of objects in the outer Solar System. Students will then examine how the orbits of the planets are different from one another, and how planetary orbits are different from other classes of objects.



### STUDENT MATERIALS

(PER STUDENT OR PAIR OF STUDENTS)

- Transparent tape
- Protractor
- Meter stick or a long ruler
- Calculator
- 2 paper clips
- 1 piece of string, at least 375 cm (148 in) in length
- Pen or pencil (Optional: 8 different colors)
- 1 large sheet of paper, approximately 100 cm × 100 cm (39 in × 39 in); two poster-size papers taped together works well
- Student Worksheet 3

### PREPARATION & PROCEDURES

1. Each student or pair of students will need a desk or a table at least as large as their poster-sized paper. Alternatively, the students could use the floor if there is not enough desk space.
2. The students will cut up the string in Activity 2 to draw the orbits of several objects in the Solar System. The length of string listed above is enough for all objects as well as 6 cm (2.4 in) to tie a knot in each end of each piece of string. If the students require more string to tie the knots, adjust the total length of the string accordingly. Students will draw the orbits of eight objects.
3. Discuss with the students how the Sun dictates the orbits of all Solar System objects. For example, ask the students: Why does the Earth (and everything else in the Solar System) orbit the Sun? (*Desired answer: the Sun makes up 99.8% of the mass in the Solar System, and therefore dictates the motion of all other objects in it*) Discuss with students how Johannes Kepler discovered that the planets orbit the Sun in an ellipse. Where do the students think the Sun is located? (*Desired answer: at one of the foci; see Science Overview for more information*) Discuss with students how the planetary motions can be explained with the theory of gravitation.



- Models can help us explore things that may otherwise be too large (or small) for us to understand. Based on what was learned during Activity 1, ask students what they would need to know about a planet's orbit in order to make a scale model of it. (*Desired answer: they would need to know the major axis and the eccentricity of the planet's orbit. They would also need to know the scale at which they are to make the model, and the orbit's orientation in space—the direction in which the ellipse's major and minor axes are oriented.*)
- Have students work individually or in pairs to explore orbits in the Solar System by following the procedures in Student Worksheet 3. The students will create a two-dimensional model of the orbits of a few Solar System objects using the scale  $1 : 1.496 \times 10^{13}$ ; that is, one Astronomical Unit (AU; Earth-Sun distance) in reality equals 1 cm in the model.

#### REFLECTION & DISCUSSION

- Discuss the results with the students. What is common to all planets? (*Desired answer: all orbits are elliptical, some more eccentric than others*) How are they oriented with respect to one another? (*Desired answer: they all lie on different axes*) How are cometary orbits different? (*Desired answer: they are much more elliptical than planetary orbits*) Is there anything that surprises them?
- Remind students that they have created a two-dimensional model of the orbits. In reality, there is also the third dimension (“up” or “down”); not everything in the Solar System orbits the Sun in exactly the same plane. One way to understand this effect is to imagine that each orbit is drawn on a different piece of paper and the papers are tilted with respect to each other. The angle of the tilt is called “inclination”—but it is not the topic of this lesson. The reason for reminding students about this effect is to make sure they realize that the orbits are located in three-dimensional space.
- Discuss with students that even within a class of objects (“asteroids” or “Kuiper Belt Objects”) there is variation in the orbital characteristics. For example, asteroid Vesta has a low eccentricity (0.0895), while Pallas (the orbit of which the students drew) has a higher eccentricity (0.2299).

#### TRANSFER OF KNOWLEDGE

Have the students plot an object whose orbit has an eccentricity of 0.0347 and whose major axis is 86.622 AU long. Ask them to which group it belongs, planets or Kuiper Belt Objects. (*This is the orbital information for Quoar, a large Kuiper Belt Object.*)

## Round and Round We Go

Lesson at a Glance

Science Overview

### Conducting the Lesson

Warm Up &  
Pre-Assessment

Activity 1:  
Ellipses are Eccentric!

Activity 2:  
The Eccentricities of  
Solar System Objects:  
How Crazy Are They?

Lesson Wrap-Up

Resources



## ASSESSMENT CRITERIA FOR ACTIVITY 2

## 5 Points

- Student accurately completed Table 1 in Student Worksheet 3.
- Student accurately drew the orbits of the objects described in Table 1 of Student Worksheet 3.
- Student accurately answered the questions on Student Worksheet 3.
- Student accurately plotted and classified the orbit of the mystery object (Quoar).

## 4 Points

- Student accurately completed Table 1 in Student Worksheet 3.
- Student accurately drew the orbits of the objects described in Table 1 of Student Worksheet 3.
- Student accurately answered most questions on Student Worksheet 3.
- Student accurately plotted and classified the orbit of the mystery object (Quoar).

## 3 Points

- Student completed mostly accurately Table 1 in Student Worksheet 3.
- Student mostly accurately drew the orbits of the objects described in Table 1 of Student Worksheet 3.
- Student accurately answered most of the questions on Student Worksheet 3.
- Student accurately plotted and classified the orbit of the mystery object (Quoar).

## 2 Points

- Student accurately filled in part of Table 1 in Student Worksheet 3.
- Student drew accurately the orbits of some of the objects described in Table 1 of Student Worksheet 3.
- Student accurately answered some of the questions on Student Worksheet 3.
- Student accurately plotted and classified the orbit of the mystery object (Quoar).

## 1 Point

- Student attempted to fill in part of Table 1 in Student Worksheet 3.
- Student attempted to draw the orbits of the objects described in Table 1 of Student Worksheet 3.
- Student attempted to answer the questions on Student Worksheet 3.
- Student attempted to plot and classify the orbit of the mystery object (Quoar).

## 0 Points

- No work completed.

**EXTENSIONS**

Have students research orbits in other contexts. How do moons go around the planets? How eccentric are their orbits? What about the rings of the giant outer planets? Do stars—including the Sun—go around the center of the Milky Way galaxy in elliptical orbits?

**PLACING THE ACTIVITY WITHIN THE LESSON**

By plotting the orbits of the Solar System objects, students should understand the general layout of the Solar System. They should also understand that orbital characteristics can provide clues as to whether a given object could be considered a real planet or whether it might be better categorized as something else. However, orbital characteristics alone are not sufficient to make the determination.

**NOTES ON ACTIVITY 2:****Round and Round We Go**

Lesson at a Glance

Science Overview

**Conducting the Lesson***Warm Up & Pre-Assessment**Activity 1:  
Ellipses are Eccentric!**Activity 2:  
The Eccentricities of  
Solar System Objects:  
How Crazy Are They?**Lesson Wrap-Up*

Resources

## LESSON WRAP-UP

### LESSON CLOSURE

Discuss with students the different kinds of orbits in the Solar System: planetary vs. cometary orbits and those in between. Discuss how the different kinds of objects “experience” the Solar System—the planets which are pretty much at the same distance from the Sun during their orbit, vs. the comets which spend much of their time in the frigid outer Solar System and then swing in to be heated up by the Sun.

Students use previous knowledge, as well as what they now know about orbits in the Solar System, to discuss whether they think Pluto should be considered a planet, as it used to be, or another kind of object (such as a dwarf planet, which is its current classification.)

### TRANSFER OF KNOWLEDGE FOR THE LESSON

Have the students research the discovery of Pluto, and why it was classified as a planet. Have them make a decision as to whether or not they think Pluto still should be classified as a planet or was the decision by the International Astronomical Union in 2006 to reclassify it correct. Have students write a short essay to support their opinion. Students should use information about Pluto’s orbit that they learned in class as well as its size, composition, and history to support their argument. Have students form teams according to which side of the issue they are on, and have the teams debate the topic during class. Have students use the points in their essay to argue their side.

*Sample argument: Pluto does not seem to fit comfortably within the family of planets in the Solar System, with which it has been historically associated. The major planets (with the exception of Mercury) all orbit the Sun in almost perfect circles. The eccentricity of Pluto’s orbit is quite high, similar to those of some asteroids, comets, and Kuiper Belt Objects. Pluto does not fit neatly in either of the two main categories of planets. Like a terrestrial planet, it is small, but, because it probably is made of a mixture of rock and ice, its density is low, like that of a Jovian planet. It most certainly is not a gas giant, but it is in the outer part of the Solar System. In fact, Pluto was reclassified in 2006 as a “dwarf planet”, a new category of objects similar to planets in many ways but too small to be considered real planets.*

You can have students read discussion on the Internet on Pluto’s reclassification as a dwarf planet (see the *Internet Resources & References* section) and see how their arguments compare with the International Astronomical Union’s decision.



ASSESSMENT CRITERIA FOR THE LESSON

5 Points

- ▶ All worksheets were completed accurately and thoroughly.
- ▶ Student's *Transfer of Knowledge* essay presented their information convincingly.
- ▶ Student's arguments during the debate were well supported.

4 Points

- ▶ All worksheets were completed thoroughly.
- ▶ Student's *Transfer of Knowledge* essay presented their information with ease.
- ▶ Student's arguments during the debate were adequately supported.

3 Points

- ▶ All worksheets were completed.
- ▶ Student's *Transfer of Knowledge* essay presented most information with ease.
- ▶ Student's arguments during the debate were supported.

2 Points

- ▶ All worksheets were mostly completed.
- ▶ Student's *Transfer of Knowledge* essay showed adequate understanding of the topic.
- ▶ Student's arguments during the debate were supported, but relevance was questionable.

1 Point

- ▶ Student attempted to answer all worksheets.
- ▶ Student's *Transfer of Knowledge* essay showed little understanding of the topic.
- ▶ Student's arguments during the debate were not supported.

0 Points

- ▶ No work completed.

Round and Round We Go

Lesson at a Glance

Science Overview

Conducting the Lesson

*Warm Up & Pre-Assessment*

*Activity 1: Ellipses are Eccentric!*

*Activity 2: The Eccentricities of Solar System Objects: How Crazy Are They?*

*Lesson Wrap-Up*

Resources

## EXTENSIONS FOR THE LESSON

Kepler's third law states that the square of the time it takes an object to orbit the Sun is proportional to the cube of half of the length of the orbit's major axis, and approximately equal if the length of the year is in Earth years, and the length of the major axis is in AU (one AU = one astronomical unit = the average distance between the Earth and the Sun). In other words

$$(\text{Orbital Period in Years})^2 \approx (1/2 \times \text{Length of Major Axis in AU})^3$$

Using this formula, have students calculate the orbital periods of the planets and comets in this lesson. Use reference sources (textbooks, the Internet) to examine how well the calculated approximate values match the actual orbital periods.

CURRICULUM  
CONNECTIONS

*Language Arts:* Review the format of a debate and have students practice expressing and supporting their opinions respectfully.

*History:* During the *Transfer of Knowledge for the Lesson* section, students research the history of the discovery of Pluto. Have them research the discovery of Uranus and Neptune, or the formulation, early controversy, and eventual acceptance of the Heliocentric Theory.

LESSON  
ADAPTATIONS*Gifted and Talented:*

Have the students calculate their scale model by looking up the information about the planets and then deciding what scale would work best for their purposes, instead of using the  $1 : 1.496 \times 10^{13}$  (1 AU = 1 cm) scale model provided in Student Worksheet 3.

Have students find the orbital inclination of the planets and create a 3-D model of the Solar System. The students could use wire to represent the orbits rather than draw them on paper.

*ESL:* Have students create a poster which visually supports their opinion regarding Pluto's status as a planet or a dwarf planet, instead of writing an essay.

**NOTES:**

**Round and Round We Go**

Lesson at a Glance

Science Overview

**Conducting the Lesson**

*Warm Up & Pre-Assessment*

*Activity 1:  
Ellipses are Eccentric!*

*Activity 2:  
The Eccentricities of  
Solar System Objects:  
How Crazy Are They?*

*Lesson Wrap-Up*

Resources

## RESOURCES

### INTERNET RESOURCES & REFERENCES

#### *Student-Friendly Web Sites:*

Astro for Kids

[www.astronomy.com/asy/default.aspx?c=ss&id=127](http://www.astronomy.com/asy/default.aspx?c=ss&id=127)

Astronomy for Kids

[www.frontiernet.net/~kidpower/astronomy.html](http://www.frontiernet.net/~kidpower/astronomy.html)

KidsAstronomy.com (Solar System)

[www.kidsastronomy.com/solar\\_system.htm](http://www.kidsastronomy.com/solar_system.htm)

Online Explorations

[amazing-space.stsci.edu/resources/explorations/](http://amazing-space.stsci.edu/resources/explorations/)

Manipulating Ellipses

[chickscope.beckman.uiuc.edu/explore/eggmath/shape/pins.html](http://chickscope.beckman.uiuc.edu/explore/eggmath/shape/pins.html)

NASA for Students

[www.nasa.gov/audience/forstudents/5-8/](http://www.nasa.gov/audience/forstudents/5-8/)

Star Child

[starchild.gsfc.nasa.gov](http://starchild.gsfc.nasa.gov)

#### *Teacher-Oriented Web Sites:*

American Association for the Advancement of Science, Project 2061

[www.project2061.org/tools/benchol/bolframe.htm](http://www.project2061.org/tools/benchol/bolframe.htm)

Discussion about Pluto's reclassification as a dwarf planet

[www.voyagesolarsystem.org/pluto/pluto\\_default.html](http://www.voyagesolarsystem.org/pluto/pluto_default.html)

NASA Quest

[quest.arc.nasa.gov/sso/teachers/](http://quest.arc.nasa.gov/sso/teachers/)

National Science Education Standards

[www.nap.edu/html/nses/](http://www.nap.edu/html/nses/)

National Space Science Data Collection (NSSDC) (data for orbits):

[nssdc.gsfc.nasa.gov/planetary/](http://nssdc.gsfc.nasa.gov/planetary/)

The Nine Planets

[www.nineplanets.org/](http://www.nineplanets.org/)

Pro-Teacher

[www.proteacher.com/110066.shtml](http://www.proteacher.com/110066.shtml)

StarDate Online

[stardate.org/resources/ssguide/](http://stardate.org/resources/ssguide/)

Voyage: A Journey through Our Solar System

[www.voyagesolarsystem.org](http://www.voyagesolarsystem.org)

Journey through the Universe

[www.journeythroughtheuniverse.org](http://www.journeythroughtheuniverse.org)



**TEACHER ANSWER KEY****STUDENT WORKSHEET 1**

1. Further apart: ellipse becomes more stretched out. Closer together: ellipse becomes more circular.
2. Smaller: ellipse becomes more “squashed.” Longer: ellipse becomes more circular.
3. Yes. You would need a very short string.
4. Yes. You would need a very long string.
5. It is a combination of the two. (More specifically, it is the ratio of the two, but the students cannot be expected to know this yet.) If the length of the string is much longer than the distance between the foci, you will get a circular shape. If the values are similar, then you will get a very elliptical shape.

**STUDENT WORKSHEET 2**

1. a. A circle  
b. Eccentricity = 0
2. a. A line  
b. Eccentricity = 1. No ellipse can really have this eccentricity.
3. No. The shape of the ellipse would be the same, but the ellipse might be bigger or smaller than what is on the friend’s picture. To draw the exact same kind of ellipse, you would need to know either the length of the major axis or the distance between the foci.
4. If the eccentricity of the ellipse is 0.9 and the major axis 20 cm, the distance between the foci is  $0.9 \times 20 \text{ cm} = 18 \text{ cm}$ .

**Round and Round We Go**

Lesson at a Glance

Science Overview

Conducting the Lesson

**Resources***Internet Resources & References**Teacher Answer Key*

## STUDENT WORKSHEET 3

Answers from Table 1

Object	Distance between foci (AU)	Distance between foci (model; cm)
Jupiter	0.51	0.51
Saturn	1.09	1.09
Uranus	1.77	1.77
Neptune	0.66	0.66
Pluto (dwarf planet)	18.80	18.80
Halley's Comet	34.80	34.80
Pallas (asteroid)	1.27	1.27
Ixion (Kuiper Belt Object)	18.94	18.94

See page 28 for a sample drawing of the eight objects in Table 1.

*Questions*

1. The orbits of the planets have low eccentricities—they are pretty circular. The dwarf planet Pluto has high eccentricity. The orbits are also oriented in different directions from each other. The sizes of the orbits are different, as well.
2. The orbits of all Solar System objects orbiting the Sun are ellipses with the Sun in one focus. The planetary orbits drawn (Jupiter, Saturn, Uranus, and Neptune) are different from the orbits of the asteroid Pallas, the dwarf planet Pluto, the Kuiper Belt Object Ixion, and Halley’s Comet—they are much more circular.
3. The distances between the inner planets are much smaller than those between the outer planets.
4. Answers for Hale-Bopp

Object	Distance between foci (AU)	Distance between foci (model; cm)
Comet Hale-Bopp	498	498

No, you could not. You would need a much larger paper (in fact, over 10 times as large).

Round and Round We Go

Lesson at a Glance

Science Overview

Conducting the Lesson

Resources

Internet Resources & References

Teacher Answer Key

Example of results of Activity 2

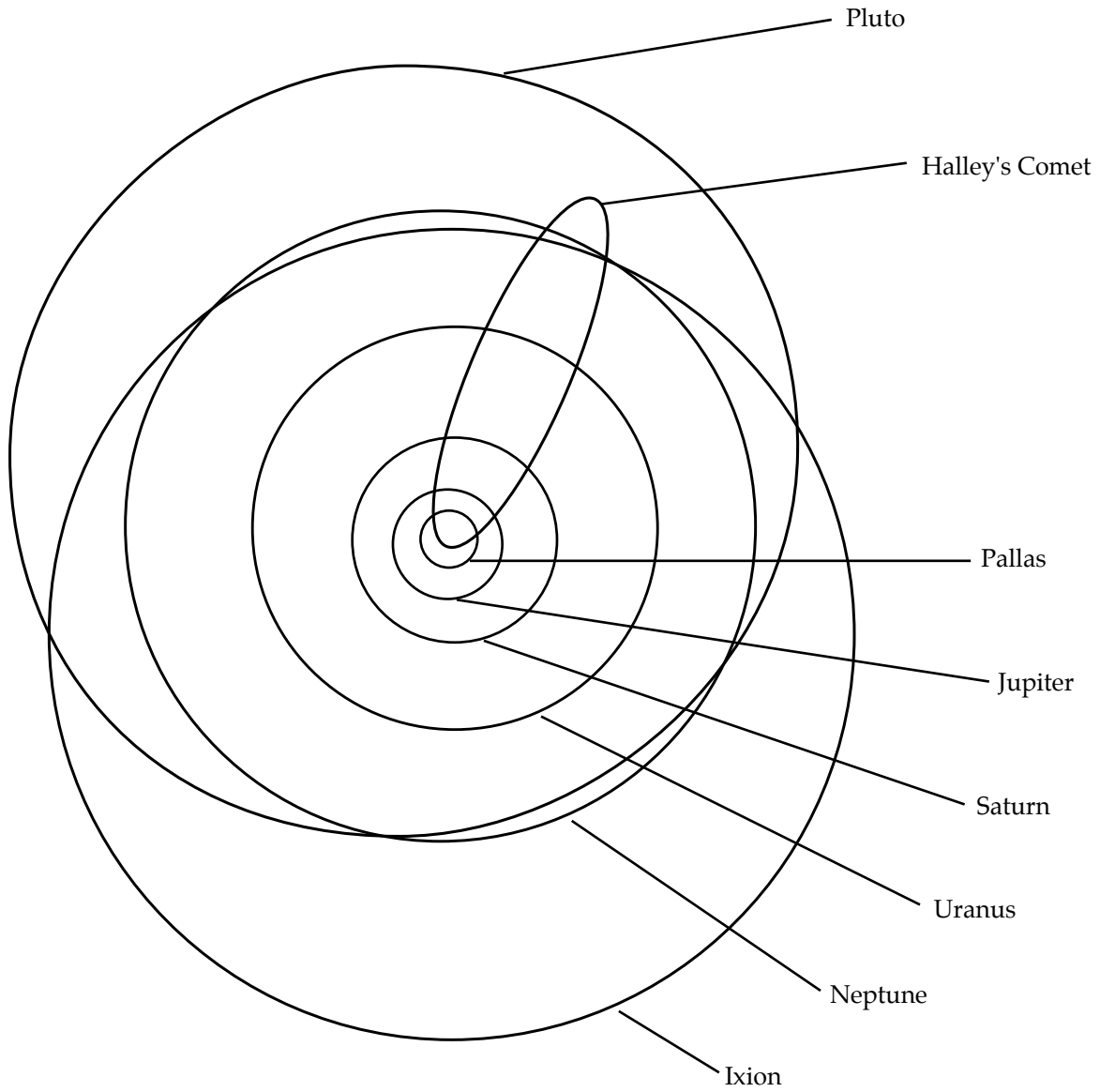

# STUDENT WORKSHEET 1: ELLIPSES ARE ECCENTRIC!

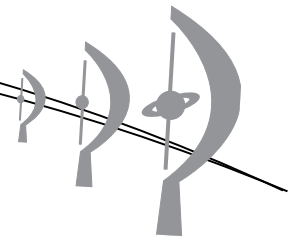

NAME \_\_\_\_\_ DATE \_\_\_\_\_

## BACKGROUND INFORMATION:

An ellipse is a geometrical shape that looks like a squashed circle. It is easy to draw one. Place two fixed points on a piece of paper. Tie a string around each of the fixed points, and draw a curve by pulling the string taut and sweeping it around the paper with a pen or pencil (see Figure S1). The places where the two fixed points are located are called the ellipse's foci (plural of focus). The length of the long axis of the ellipse is called its major axis (see Figure S2). The small axis perpendicular to the major axis is called the minor axis.

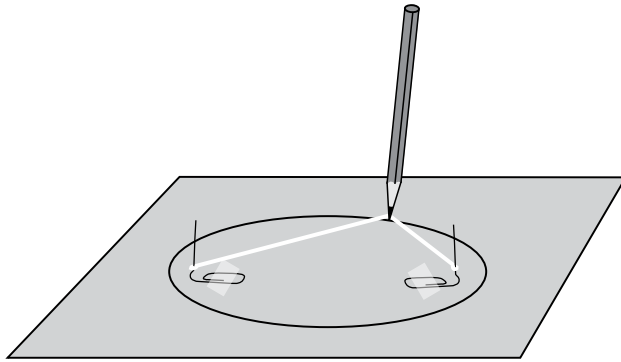

Figure S1. How to draw an ellipse with two paper clips, string, and a pencil.

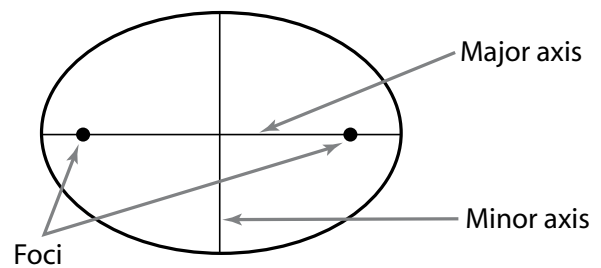

Figure S2. The properties of an ellipse can be described by the location of its foci and the lengths of its major and minor axes.

## MATERIALS:

- ▶ 2 paper clips
- ▶ Transparent tape
- ▶ Pen or pencil
- ▶ String (at least 25 cm, or 10 inches, long)
- ▶ Scissors
- ▶ A piece of paper
- ▶ Colored pencils

## Procedures:

1. Cut a piece of string approximately 25 cm long.
2. Lie two paper clips flat on the table, and bend the end of the wire straight up in the air. Tape the paper clips on the paper about 5 cm apart.
3. Tie each end of the string to one of the paper clips.



4. Pull the string taut with a colored pencil, and sweep the pencil along the string, keeping the string taut, in order to draw half of the ellipse (see Figure S1 for the setup.) Remove the pencil, move the string to the other side of the paper clips from the half of the ellipse you just drew, place the pencil back along the string, and sweep it along the string to draw the other half of the ellipse.
5. Put a dot where your paper clips are to mark the location of your foci. Now take one of the paper clips and move it a little further away from the first, so that the distance between the foci is about 12 cm. Repeat Step 4 with a different color pencil to draw another ellipse.
6. Untie one end of the string from the paper clip, and re-tie it so that the knot is further up the string—that is, so that the length of the string between the knots is shorter than before. Repeat Step 4 with a different color pencil to draw yet another ellipse.
7. Again mark with your pencil or pen where the foci are located. Experiment making ellipses with different distances between the foci, and different lengths of string. Make sure that at each time the length of the string is a little longer than the distance between the foci—otherwise you cannot draw an ellipse! Once you have made four or five ellipses, each in a different color, answer the questions below.

#### QUESTIONS

1. What happens to the ellipse when the foci get further apart? Closer together?
2. What happens to the ellipse when the length of the string between the knots gets shorter? Longer?
3. Could you make a very elliptical (“squashed”) ellipse if you had the foci close together? What would you need?
4. Could you make a very round ellipse if you had the foci far apart? What would you need?
5. Based on your observations, what is the parameter that defines an ellipse? Is it the distance between the foci, the length of string, or some combination of the two? Explain.









**STUDENT WORKSHEET 3:  
THE ECCENTRICITY OF SOLAR SYSTEM OBJECTS**

NAME \_\_\_\_\_ DATE \_\_\_\_\_

**MATERIALS:**

- ▶ 2 paper clips
- ▶ 1 piece of string, at least 375 cm (148 in) in length
- ▶ Pen or pencil (Optional: 8 different colors)
- ▶ 1 sheet of paper approximately 100 cm × 100 cm (39 in × 39 in)
- ▶ Transparent tape
- ▶ Protractor
- ▶ Meter stick or a ruler
- ▶ Calculator

**BACKGROUND INFORMATION:**

All objects that go around the Sun travel along paths called orbits. The shapes of all orbits are ellipses of different sizes, eccentricities, and orientations. In all cases, the Sun is located at one of the foci. You will be making a scale model of the Solar System by drawing the orbits of a few planets and other objects in the Solar System.

Relevant equation:  $Eccentricity = \frac{\text{distance between foci}}{\text{length of major axis}}$

**PROCEDURES:**

1. Using Table 1, determine the distance between the foci for each object, based on the eccentricities and sizes of the major axes for the model you will make. Add the results in the appropriate columns in the Table.
2. Tape the paper to your desk or on the floor so that you have a comfortable work surface.
3. Place a dot in the center of the paper to represent the Sun.
4. Using a meter stick, draw a line through the Sun horizontally across the paper. This line will represent the orientation of the Earth's orbit in the Solar System.
5. Create the orbit of Jupiter:
  - a. The foci of different orbits are not usually on the same line, so you need to determine the orientation of each of the orbits. To do so for Jupiter, find Jupiter's orientation in Table 1, and measure the angle from Earth's orientation using your protractor. If the angle is positive, measure the angle counter-clockwise above the Earth line; if the angle is negative, measure it clockwise below the Earth line.
  - b. Draw a faint guideline from the Sun through this angle. This line represents the orientation of Jupiter's orbit in space, compared to Earth's.
  - c. To find the other focus of Jupiter's orbit, find the distance between the foci on Table 1, measure the distance from the Sun focus along Jupiter's line of orientation, and mark the location of the other focus.



- d. Tape two paper clips to the two foci, just like you did in Activity 1.
  - e. Cut the string to the length of 6 cm longer than the distance indicated in the “Major Axis (model; cm)” column in Table 1. Tie each end of the string around the paper clips. Make sure that the length of string between the knots tied to the clips is the same as the length of the “Major Axis (model; cm).” You can tie the knots on the string first to make sure the distance is right and then slide the knots onto the paper clips.
  - f. Create Jupiter’s elliptical orbit in the same manner that you created the ellipses in Activity 1.
  - g. Remove the paper clips (and the tape), and complete any part of the orbit you may not have been able to draw because of the presence of paper clips or tape.
6. Repeat the process for the other objects in Table 1. Label each orbit with the name of the object. You may want to use different colors for the different objects.

Table 1

Object	Eccentricity of orbit	Major axis (AU)	Major Axis (model; cm)	Distance between foci (AU)	Distance between foci (model; cm)	Orientation with respect to Earth’s orbit (degrees)
Jupiter	0.049	10.4	10.4			-88
Saturn	0.057	19.2	19.2			-11
Uranus	0.046	38.4	38.4			68
Neptune	0.011	60.1	60.1			-58
Pluto (dwarf planet)	0.24	78.5	78.5			121
Halley’s Comet	0.97	35.9	35.9			68
Pallas (asteroid)	0.23	5.5	5.5			21
Ixion (Kuiper Belt Object)	0.24	78.9	78.9			-93

**QUESTIONS:**

1. How are the orbits of the planets similar to one another? How are they different? How do their orbits compare with the dwarf planet Pluto's orbit?
  
2. How are the orbits of the planets similar to the orbits of the other objects? How are they different?
  
3. You have drawn the orbits of the outer planets; the orbits of the inner planets—Mercury, Venus, Earth, Mars—must fit inside of Jupiter's orbit. What does this tell you about the distances between the inner planets compared to the distances between the outer planets?
  
4. Halley's Comet is a short-period comet (the time it takes for it to go once around the Sun is 76 years, which is long from a human perspective, but short for a comet.) An example of a well-known long-term comet is Comet Hale-Bopp, which a lot of people on Earth saw in the sky in 1997 during the comet's most recent visit to the inner Solar System. It takes Comet Hale-Bopp about 4,000 years to go around the Sun once. Below is the entry for this comet for Table 1. Calculate the distance between the foci and enter them into the table below.

Object	Eccentricity of orbit	Major axis (AU)	Major Axis (model; cm)	Distance between foci (AU)	Distance between foci (model; cm)	Orientation with respect to Earth's orbit (degrees)
Comet Hale-Bopp	0.995	500	500			-50

Could you draw the orbit of Comet Hale-Bopp in your model?

